

- **2-30 MHz Frequency Range**
- **Up to 20 kW Average, 40 kW Peak Power Rating**
- **Horizontal Polarization**
- **2.0:1 Maximum VSWR**
- **Short-to-Medium-Range and Medium-to-Long-Range Communications**
- **Minimum Space Required**

General Description

The 2701 and 2702 Series antennas are horizontally polarized, log-periodic antennas, capable of radiating optimum communications frequencies at the proper elevation angle. Frequency ranges spanning the entire HF spectrum permit transmission of these frequencies at all times. The elevation angle of radiation is selected to suit the particular circuit and, since the radiation pattern is virtually independent of frequency and local ground characteristics, the elevation angle remains near optimum under all conditions.

Features

Economy. The 2701 and 2702 Series antennas are designed to supply superior performance at minimum cost. Eight graduated frequency ranges are available to provide antennas of adequate bandwidth without the cost of excess bandwidth. Towers are shipped entirely disassembled in approximately one-fifth their assembled volume to minimize shipping costs. In addition, the use of minimum land area decreases location costs.

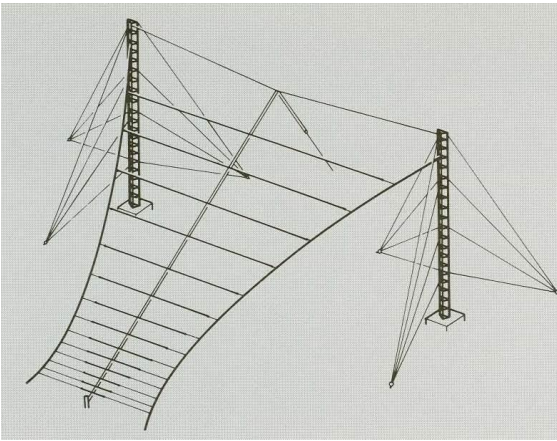

Strength and Durability.

The antennas are fabricated of materials which have a proven record of long life through use in every environment. All structural assemblies will withstand high corrosive environmental agents, such as salt spray. Towers are made of galvanized steel. Catenary support systems are made of Parafil, which is a highly reliable insulating material. The use of this material minimizes the requirement for insulator breakup of metallic members which may interfere with the electrical performance of the antennas. Fiberglass catenaries and/or aluminum alloy towers are available by special order.

Ease of Installation. Installation of the antennas is simple and rapid. All parts of the log-periodic array and its suspension system are fabricated to exact length, so that no calculation, cutting or adjustment is required for erection on level land. Built-in adjustment points are provided to permit erection on uneven terrain without modification.

Disassembled towers bolt together simply in the field to form 10-foot and 20-foot sections which are light enough to be moved about easily. Using an erection fixture as an accessory, these sections can be erected without a crane.

2701 Series, Short-to-Medium-Range.

2701 Series antennas develop a broad lobe, directed at high elevation angles in order to reach short distances. (The dashed lines in Figure 3, drawn on the assumption of one-hop transmission and reflection at a virtual height of 300 km, show that one-hop transmission to all points 60-850 miles (95-1,350 km) distant would lie within the half-power beamwidth.)

2702 Series, Medium-to-Long-Range.

In comparison with the 2701 Series, those in the 2702 Series develop a somewhat narrower lobe, directed at lower elevation angles in order to reach greater distances. (The dashed lines in Figure 3, again drawn assuming one-hop transmission and reflection at 300 km height, demonstrate that one-hop transmission to all points 200-1,200 miles (320-1,900 km) distant would lie within the half-power beamwidth.)

Longer-Distance Coverage. Antennas using the 2701/2702 curtains with an elevated apex provide optimum take-off angle versus frequency characteristics for communications at longer distances. (See Application Note Number 2-Bulletin 1537.)

Antenna systems designed to meet customer specifications regarding elevation angle pattern are available by special order.

Accessories

The following accessories are available for ease of installation and maintenance: tower lighting kit, erection kit, paint kit, tool kit, lightning rod kit, anti-climbing kit and spares kit.

Characteristics

Type	HF log-periodic
Frequency Range, MHz	2-32
Power Rating, kW	Up to 20 average, 40 peak
Polarization	Horizontal
VSWR	2.0:1 maximum
Gain, dBi	Type 2701: 10 nominal Type 2702: 11.5 nominal
Front to Back Ratio, dBi	Type 2701: 14 Type 2702: 11
Level of Largest Side or Back Lobe Relative to Main Lobe, dB	Type 2701: -14 Type 2702: -11
Wind Survival Rating, mph (km/h)	
Without Ice	100 (160)
With 0.5 in (12mm) Radial Ice	70 (100)

Radiation Patterns

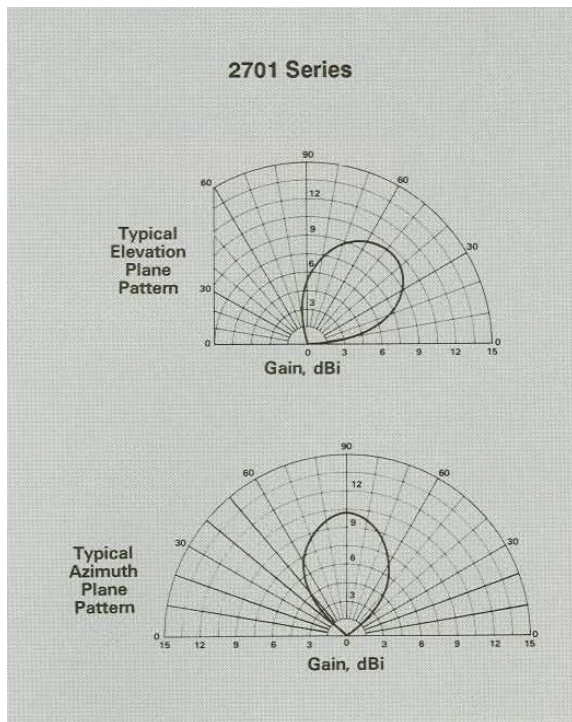

Figure 1

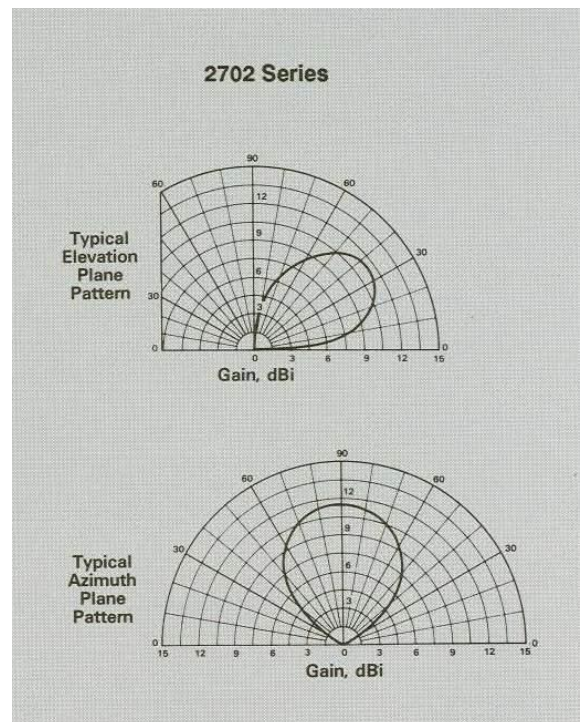

Figure 2

Elevation Plane Radiation Pattern
Superimposed on Skyway Transmission Chart

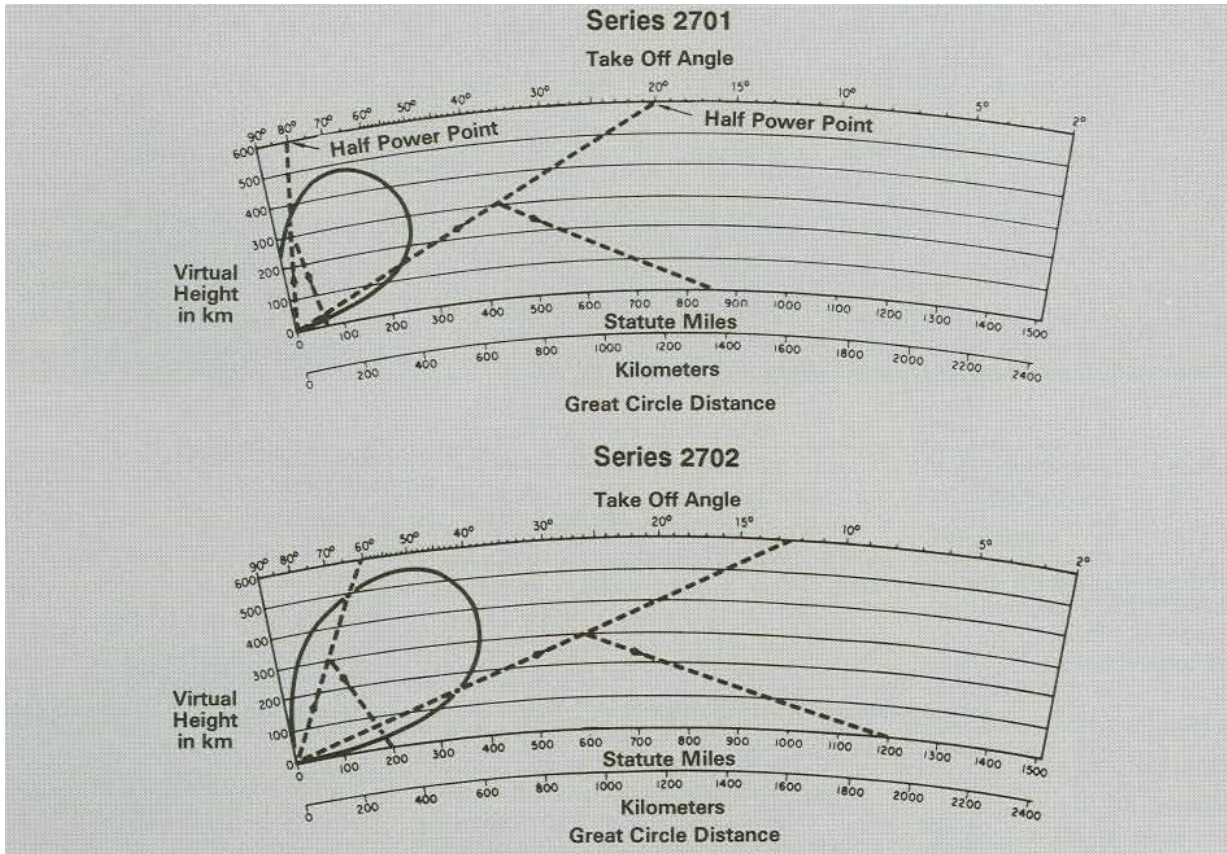
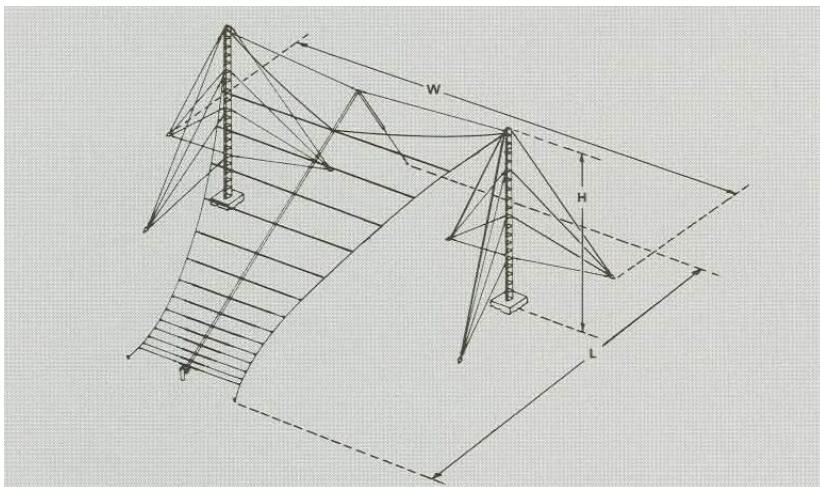

Figure 3

Antenna Dimensions



Ordering Information

Type Number	Frequency Range MHz	Length (L) ft (m)	Height (H) ft (m)	Width (W) ft (m)
2701-101-(*)	6.5-32	145 (44.2)	40 (12.2)	161 (49.1)
2701-102-(*)	5.4-32	169 (51.5)	50 (15.2)	199 (60.7)
2701-103-(*)	4.6-32	195 (59.5)	55 (16.8)	220 (67.1)
2701-104-(*)	4.0-32	227 (69.2)	65 (19.8)	265 (80.8)
2701-105-(*)	3.4-32	265 (80.8)	80 (24.4)	309 (94.2)
2701-106-(*)	2.8-32	310 (94.5)	95 (30.0)	379 (115.6)
2701-107-(*)	2.5-32	362 (110.3)	110 (33.5)	468 (142.7)
2701-108-(*)	2.0-32	452 (137.8)	140 (42.7)	590 (179.9)
2702-101-(*)	6.5-32	143 (43.6)	65 (19.8)	196 (59.8)
2702-102-(*)	5.4-32	166 (50.6)	75 (22.9)	234 (71.3)
2703-103-(*)	4.6-32	192 (58.5)	90 (27.4)	268 (81.7)
2702-104-(*)	4.0-32	224 (68.3)	105 (32.0)	321 (97.9)
2702-105-(*)	3.4-32	262 (80.0)	125 (38.1)	371 (113.1)
2702-106-(*)	2.8-32	305 (93.0)	145 (44.2)	449 (136.9)
2702-107-(*)	2.5-32	357 (108.8)	170 (51.8)	551 (168.0)
2702-108-(*)	2.0-32	445 (135.7)	215 (65.6)	695 (212.0)

* See the following table for appropriate suffix to Type Number

Type Number Suffix	Power Rating kW		Input Impedance Ohms	Input Connector
	Average	Peak		
1K	20	40	300 Balanced	Open Lines
2K	20	40	600 Balances	Open Lines
3K	20	40	50	3-1/8" EIA, female
4K	10	30	50	1-5/8" EIA female
5K	Receive Only	Receive Only	50	Type N Jack
6K	Receive Only	Receive Only	75	Type N Jack
7K	2.5	30	50	7/8" EIA female
8K	1	2	50	Type N Jack